

OUTBOARD PROFILE

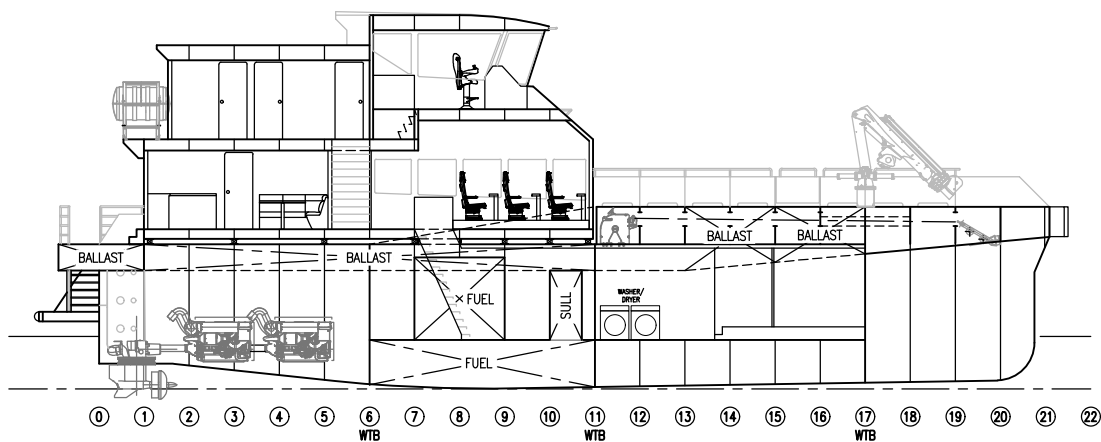

INTERNAL PROFILE

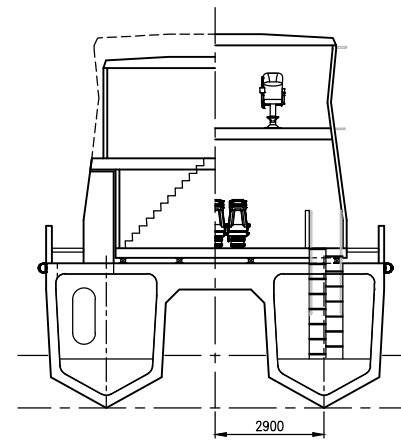

TYPICAL SECTION

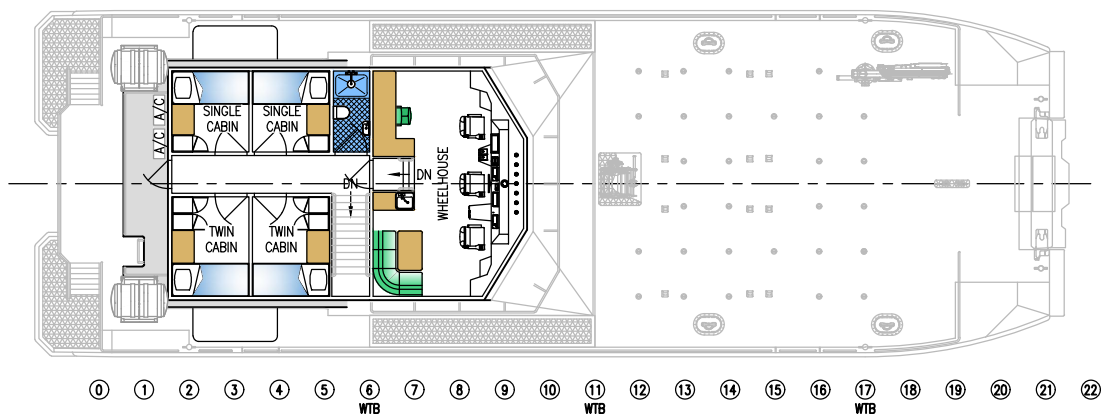

UPPER DECK

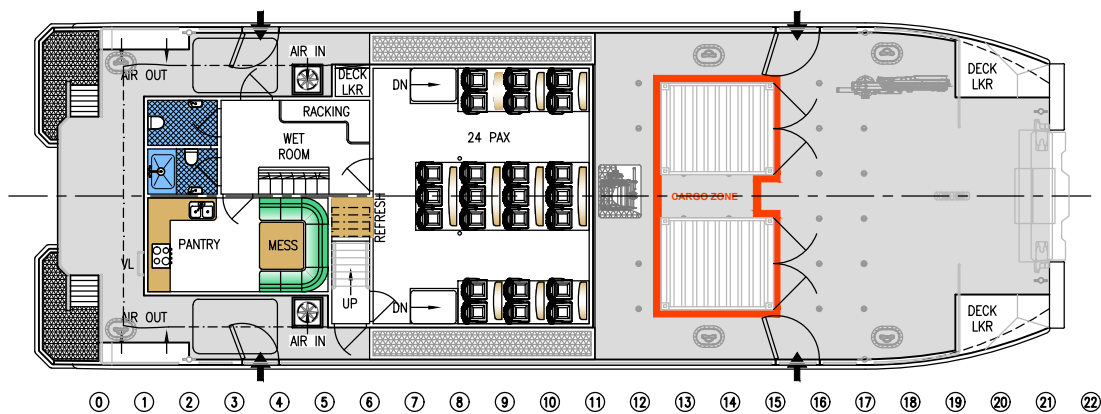

MAIN DECK

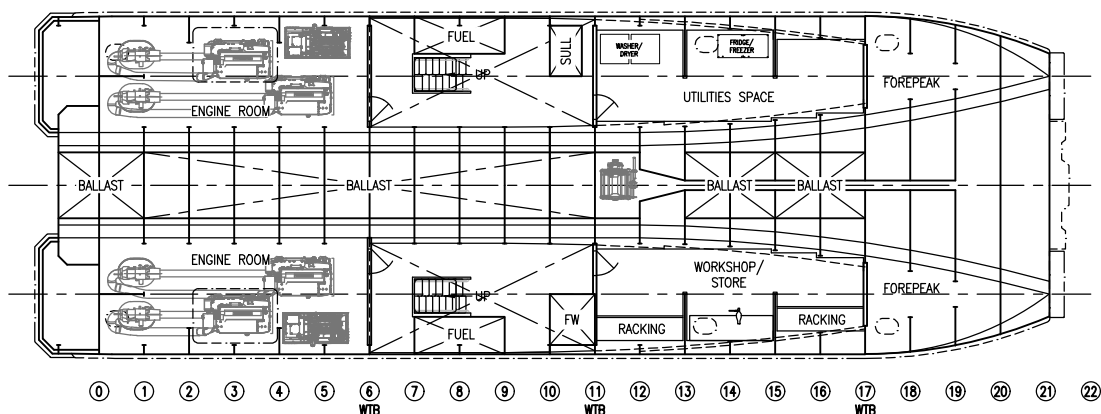

HULL PLAN

SPECIFICATIONS	
OVERALL LENGTH (EXCL APPENDAGES):	27.1m
WATERLINE LENGTH:	24.9m
MEASURED LENGTH:	24.9m
BEAM (NOT INCLUDING SPONSONS):	9.0m
DRAFT (HULL):	1.4m
PERSONNEL:	24
CREW:	6
CONSTRUCTION	
HULL:	ALUMINIUM
SUPERSTRUCTURE:	ALUMINIUM
FUEL OIL:	2 x 13 000 l
FRESH WATER:	2 x 4 750 l
SULLAGE:	1 x 3500 l
MAX DEADWEIGHT:	1 x 2500 l
FWD DECK AREA:	40t
AFT DECK AREA:	72m²
	10m²
MACHINERY	
MAIN ENGINES:	4 x VOLVO PENTA D13
RATED POWER:	4 x 515kW @ 2250 rpm
PROPULSION:	4 x VOLVO IPS 900
GENSETS:	2 x 35 kW

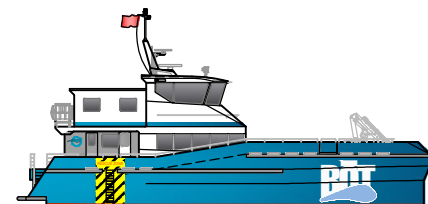

INCAT CROWTHER
YOUR VISION. OUR INNOVATION.

EUROPE OFFICE
2 Sleepy Hollow, Angfield Hill
Romsey, SO51 9AW, UNITED KINGDOM
T +44 23 8021 1720
info@incatcrowther.com www.incatcrowther.com

PROPRIETARY INFORMATION - COPYRIGHT All Rights Reserved
In compiling this document, Incat Crowther relies upon information supplied by a number of external sources. The document is supplied on the basis that while Incat Crowther believes all the information in it will be correct at the time of publication, it does not warrant its accuracy or completeness and to the full extent allowed by law excludes liability in contract, tort, or otherwise, for any loss or damage sustained by the reader, or by any other person or body corporate arising from or in connection with the supply or use of the whole or any part of the information in this document. Incat Crowther (UK) LLP, 00396436

PROJECT TITLE			
CATAMARAN CTV			
DOCUMENT TITLE			
GENERAL ARRANGEMENT - 27M - QUAD IPS			
PROJECT NO.	SHEET	SCALE	
IC22047	01	1:100	
DOCUMENT NO.	REV.	PAPER	
011-05-01	P1	A1	
DIMENSIONS IN MILLIMETRES UNLESS NOTED			DO NOT SCALE

P1	PRELIMINARY ISSUE	DMM	ED	26MAY22
REV.	REVISION DESCRIPTION	PREP.	CHECK	REV. DATE